

PRELIMINARY TECHNICAL DATA



± 300 deg/s Single Chip Yaw Rate Gyro with Signal Conditioning

Preliminary Technical Data

ADXRS300*

FEATURES

Complete Rate Gyroscope on a Single Chip
Z Axis or Yaw rate response
High Vibration rejection over wide frequency
2000g Powered Shock Operation
Self-Test on Digital Command
Temperature Sensor Output
Precision Voltage Reference Output
Absolute Rate Output for Precision Applications
+5V Single Supply Operation
Ultra small and light (<150mm², <1 gram)

APPLICATIONS

- Vehicle Chassis Rollover Sensing
- Inertial measurement units
- Platform stabilization

GENERAL DESCRIPTION

The ADXRS300 is a complete angular rate sensor, (gyroscope) which uses Analog Devices surface-micro-machining process to make a functionally complete and low cost angular rate sensor integrated with all of the required electronics.

The ADXRS300 operates on the principle of a resonator or “tuning fork” gyro. Two polysilicon sensing structures each contain a dither frame which is electrostatically driven to

resonance. This produces the necessary velocity element to produce a Coriolis force during angular rate. At two of the outer extremes of each frame, orthogonal to the dither motion, are movable fingers that are placed between fixed pickoff fingers to form a capacitive pickoff structure which sense Coriolis motion. The resulting signal is fed to a series of gain and demodulation stages that produce the electrical rate signal output. The dual sensor design rejects external g-forces and vibration. Fabricating the sensor with the signal conditioning electronics preserves signal integrity in noisy environments.

The output signal, RATEOUT(1B,2A), is a voltage proportional to angular rate about the axis normal to the top surface of the package. A single external resistor can be used to lower the scale factor. An external capacitor is used to set the bandwidth. Other external capacitors are required for operation (*see Figure 4*). A precision reference and a temperature output are also provided for compensation techniques. Two digital self-test inputs electro-mechanically excite the sensor to test proper operation of both sensors and the signal conditioning circuits.

The manufacturing technique for this device is the same high-volume BIMOS process used to for high reliability automotive airbag accelerometers.

The ADXRS300 is available in a 7mm x 7mm x 3mm BGA surface-mount package from -40°C to $+85^{\circ}\text{C}$.

PRELIMINARY TECHNICAL DATA

ADXRS300-SPECIFICATIONS

@TA = +25°C, Vs = +5V; Angular Rate = 0 °/s, unless otherwise noted.

Parameter	Conditions	ADXRS300AQC			Units
		Min	Typ	Max	
SENSITIVITY					
Clockwise rotation is positive output					
Dynamic Range ¹	Full scale range over spec. range		+/- 300		°/s
Initial	@25 °C	4.7	5	5.3	mV/°/s
vs. Temp ²		4.7		5.3	mV/°/s
Nonlinearity	Best fit straight line		0.1		% of FS
Voltage Sensitivity	Vcc=4.75 to 5.25V		0.7		%/V
NULL					
Initial Null	See apps. note for null compensation	2.3	2.50	2.7	V
vs. Temp		2.3		2.7	V
Temperature Hysteresis of Null ³	Return after temp excursion		0.1		°/sec
Turn On Time	Power on to ± ½ °/sec of final		35		ms
Stability (after turn on time)	0.5 sec to 3 minutes from power-on		0.03		°/sec
Linear acceleration effect	Any axis		0.2		°/sec/g
Voltage Sensitivity	Vcc=4.75 to 5.25V		0.6		°/sec/V
NOISE PERFORMANCE					
Rate Noise Density	@25°C		0.2		°/s/√Hz
FREQUENCY RESPONSE					
3 dB Bandwidth (user selectable) ⁴	22 nF as comp cap (see apps. section)		40		Hz
Sensor Resonant Frequency			14		kHz
SELF TEST INPUTS					
ST1 RATEOUT Response	ST1 pin from Logic '0' to '1'		-50		°/s
ST2 RATEOUT Response	ST2 pin from Logic '0' to '1'		+50		°/s
Logic '1' Voltage	Standard high logic level definition	3.3			V
Logic '0' Voltage	Standard low logic level definition			1.7	V
Input Impedance	To Common		50		kΩ
TEMPERATURE SENSOR					
For die temperature monitoring					
V out at 298 °K			2.50		V
Max current load on pin	Sink to common			50	uA
Scale factor	Proportional to absolute temperature		8.4		mV/°K
OUTPUT DRIVE CAPABILITY					
Output Voltage Swing	Iout = 100 μA	0.25		Vs-0.25	V
Capacitive Load Drive		1000			pF
2.5 VOLT REFERENCE					
Voltage value		2.470	2.5	2.530	Volts
Load Drive to ground	Source		300		uA
Load Regulation	0 < Iout < 200uA		5.0		mV/mA
Power Supply Rejection	4.75 to 5.25 Vs		1.0		mV/V
Temperature Drift	Delta from 25°C		5.0		mV
POWER SUPPLY					
Operating Voltage Range		4.75	5.00	5.25	V
Quiescent Supply Current			5.0	8.0	mA
TEMPERATURE RANGE					
Specified Performance A grade ⁵	Temp. tested to Max and Min specs.	-40		85	°C

Notes:

- Dynamic range is the maximum full scale measurement range possible including output swing range, initial offset, sensitivity, offset drift, and sensitivity drift at 5V supplies.
- Specification refers to the maximum extent of this parameter as a worst case value at T_{min} or T_{max}.
- Repeatability of the null offset reading with returning to the same temperature after worst case operating temperature swing. Please see apps. note on temperature calibration.
- Frequency at which response is 3dB down from DC response with specified compensation capacitor value. Internal pole forming resistor is 180k Ohms. See data sheet apps.
- Part functions to below -40C. Above 85 C operation is not recommended.

All min and max specifications are guaranteed. Typical specifications are not tested or guaranteed

PRELIMINARY TECHNICAL DATA

ABSOLUTE MAXIMUM RATING:

Acceleration (any axis, unpowered, 0.5ms).....	2000g
Acceleration (any axis, powered for 0.5ms).....	1000g
+Vs.....	-0.3V to +6.0V
Output Short Circuit Duration (any pin to Common).....	Indefinite
Operating Temperature.....	-55°C to +125°C
Storage Temperature.....	-65°C to +150°C

Stresses above those listed under Absolute Maximum Ratings may cause permanent damage to the device. This is a stress rating only. Functional operation of the device at these, or any other conditions above those indicated in the operational sections of this specification is not implied. Exposure to absolute maximum rating conditions for extended periods may affect device reliability.

Drops onto hard surfaces can cause shocks of greater than 2000g and exceed the absolute maximum rating of the device. Care should be exercised in handling to avoid damage

RATE SENSITIVE AXIS

This is a Z-axis rate-sensing device, also called yaw-rate sensing. It produces a positive going output voltage for clockwise rotation about the axis normal to the package top, i.e., clockwise when looking down at the package lid.

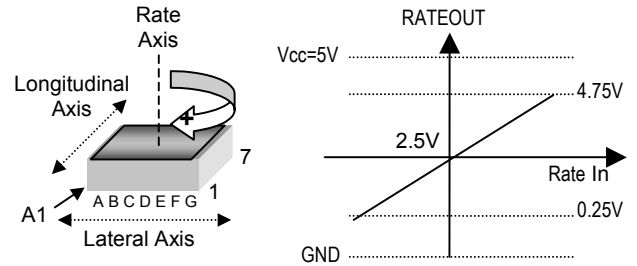
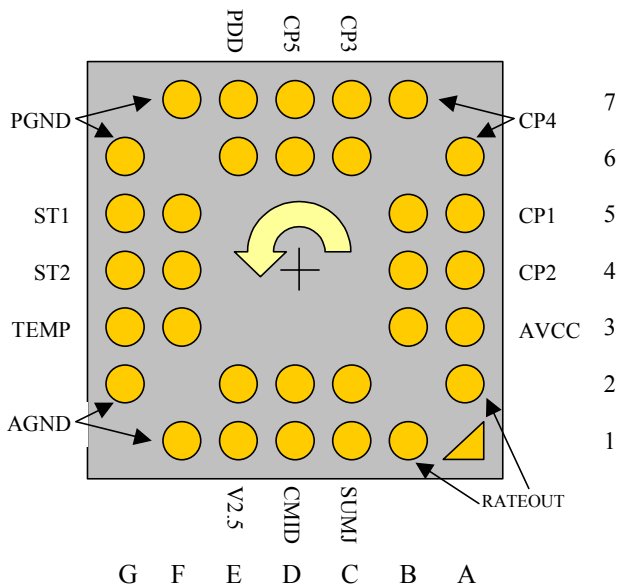

Figure 2: RATEOUT signal increases with clockwise rotation.

ORDERING GUIDE

Model	Temperature Range	Package Description	Package Option
ADXRS300AB G	-40° to +85°C	32 pad BGA	BGA-32

Figure 1: Bottom View



Pin #	Name	Description
6D, 7D	CP5	HV Filter Capacitor – 47nF
6A, 7B	CP4	Charge Pump Capacitor – 22nF
6C, 7C	CP3	
5A, 5B	CP1	Charge Pump Capacitor – 22nF
4A, 4B	CP2	
3A, 3B	AVCC	+ Analog Supply
1B, 2A	RATEOUT	Rate Signal Output
1C, 2C	SUMJ	Output Amp Summing Junction
1D, 2D	CMID	HF Filter Capacitor – 100nF
1E, 2E	V2.5	2.5 Volt Precision Reference
1F, 2G	AGND	Analog Supply Return
3F, 3G	TEMP	Temperature Voltage Output
4F, 4G	ST2	Self-Test for Sensor 2
5F, 5G	ST1	Self-Test for Sensor 1
6G, 7F	PGND	Charge Pump Supply Return
6E, 7E	PDD	+ Charge Pump Supply

Figure 3: XRS300 Pin Descriptions

PRELIMINARY TECHNICAL DATA

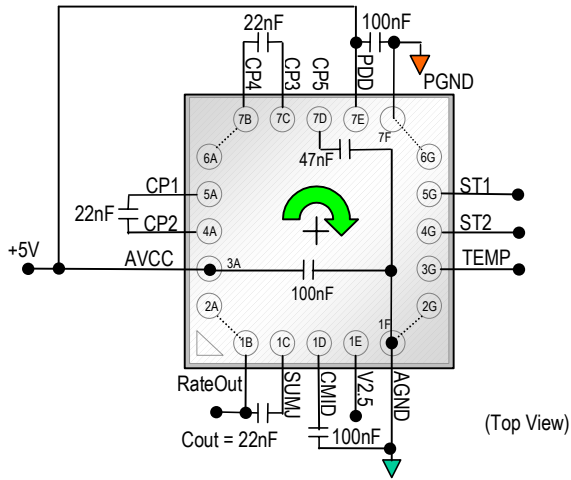

Figure 4: Example Application Circuit. A CMID capacitor of 100 nF sets a 400 Hz low pass pole $\pm 35\%$ and is used to limit high frequency artifacts before final amplification. Bandwidth limit capacitor C_{out} at 22 nF sets the pass bandwidth to 40 Hz. (See figure 3 below and Setting Bandwidth section following)

SUPPLY AND COMMON CONSIDERATIONS

Only power supplies used for supplying analog circuits are recommended for powering the ADXR300. High frequency noise and transients associated with digital circuit supplies may have adverse effects on device operation.

Figure 4 shows the recommended connections for the ADXR300 where both AVCC and PDD have a separate decoupling capacitor. These should be placed as close to their respective pins as possible before routing to the system analog supply. This will minimize the noise injected by the charge pump that uses the PDD supply.

Also recommended is to place the three charge pump capacitors connected to the CP1-CP5 pins as close to the part as possible. These capacitors used to produce the on chip high-voltage supply switched at the dither frequency at approximately 15kHz. Surface-mount chip capacitors are suitable.

If an external 14V to 16V supply is available, the two capacitors on CP1-CP4 can be omitted and this supply connected to CP5 (pin 7D) with a 100nF decoupling capacitor in place of the 47nF.

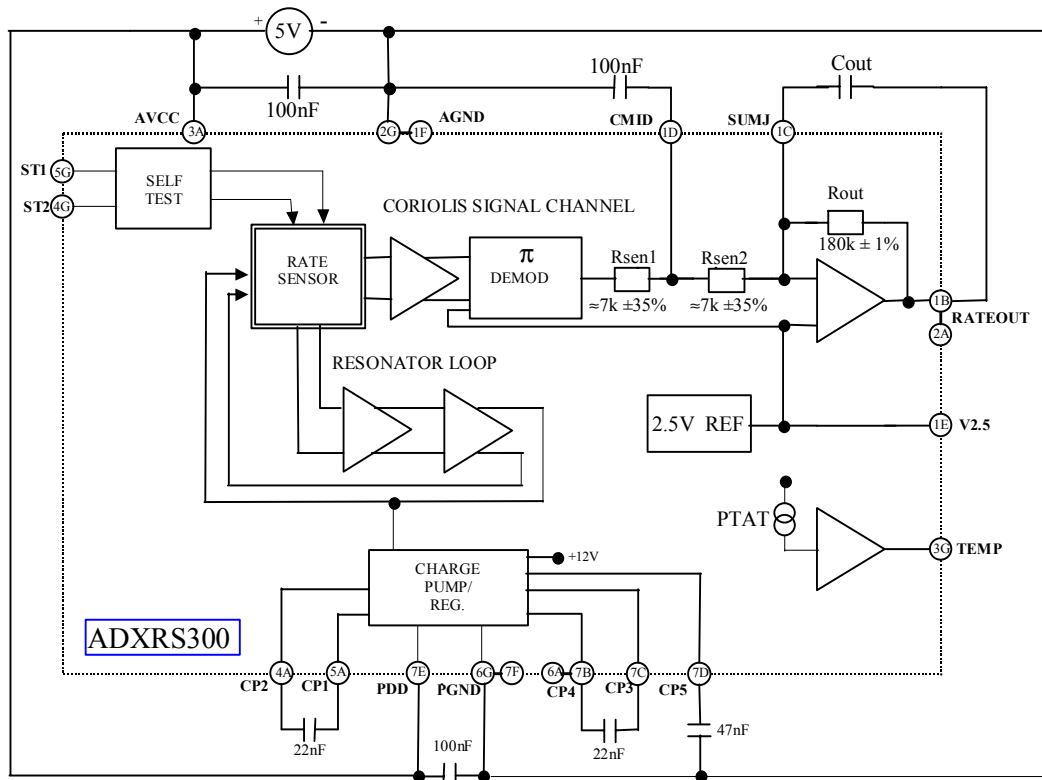

Figure 5 – ADXR300 Block Diagram with External Components

PRELIMINARY TECHNICAL DATA

SETTING BANDWIDTH

Refer to figure3. External capacitors C_{mid} and C_{out} are used in combination with on-chip resistors to create two low pass filters to limit the bandwidth of the ADXRS300's rate response. The $-3dB$ frequency set by R_{out} and C_{out} is:

$$f_{out} = 1 / (2 * \pi * R_{out} * C_{out})$$

and can be well controlled since R_{out} has been trimmed during manufacture to be $180k\Omega \pm 1\%$. Any external resistor applied between RATEOUT(1B, 2A) and SUMJ(1C) pins, will result in

$$R_{out} = 180K\Omega // R_{ext}$$

The $-3dB$ frequency set by R_{sen} (the parallel combination of R_{sen1} and R_{sen2}) at about $3.5K\Omega$ nominal and C_{mid} is less well controlled since R_{sen1} and R_{sen2} have been used to trim the rate sensitivity during manufacture and have a $\pm 35\%$ tolerance. Its primary purpose is to limit the high frequency demodulation artifacts from saturating the final amplifier stage. Thus, this pole of nominally $400 Hz @ 0.1 \mu F$, need not be precise. Lower frequency is preferable but its variability usually requires it to be at least higher than the well-controlled output pole. In general both $-3dB$ filter frequencies should be set as low as possible to reduce the amplitude of these high frequency artifacts as well as to reduce overall system noise.

INCREASING MEASUREMENT RANGE

The full-scale measurement range of the ADXRS300 can be increased by placing an external resistor between the RATEOUT(1B, 2A) and SUMJ(1C) pins which would parallel the internal R_{out} resistor that is factory-trimmed to $180K\Omega$. For example, a $330K\Omega$ external resistor will give $\sim 50\%$ increase in the full-scale range. This is effective for up to a 4X increase in the full-scale range (minimum value of the parallel resistor allowed is $45K\Omega$). Beyond this amount of external sensitivity reduction, the internal circuitry headroom requirements prevent further increase in linear full-scale output range. The drawbacks of modifying the full-scale range are the additional output null drift (as much as $2^\circ/sec$ over temperature) and the re-adjustment of the initial null bias (See section on Null Adjust).

USING THE ADXRS300 WITH A SUPPLY-RATIOMETRIC ADC

The ADXRS300's RATEOUT signal is non-ratiometric; i.e., neither the null voltage nor the rate sensitivity is proportional to supply. Rather, they are nominally constant for D.C. supply changes within the 4.75 to 5.25v operating range. If the ADXRS300 is to be used with a supply-ratiometric ADC, the ADXRS300's 2.5v output can be converted and used to make corrections in software for the supply variations.

NULL ADJUST

Null adjustment is made possible by injecting a suitable current to SUMJ(1C). Adding a suitable resistor to either ground or the positive supply is a simple way of achieving

this. The nominal 2.5 V null is for symmetrical swing range at RATEOUT(1B, 2A). However, a non-symmetric output swing may be suitable in some applications. Note that if a resistor is connected to the positive supply, then supply disturbances may reflect some null instabilities. Digital supply noise is to be particularly avoided in this case. (See Supply and Common Considerations).

The value of the resistor to use is approximately:

$$R_{null} = (2.5 * 180,000) / (V_{null0} - V_{null1})$$

V_{null0} is the un-adjusted zero rate output; V_{null1} is the target null value. If the initial value is below the desired value the resistor should terminate on common, or ground. If it is above the desired value, the resistor should terminate on the 5V supply. Values typically are in the 1-5 M Ω range

If an external resistor is used across RATEOUT and SUMJ then the parallel equivalent value is substituted into the above equation. Note that the resistor value is an estimate as it assumes $V_{cc} = 5.0$ volts and $V_{SUMJ} = 2.5$ Volts.

SELF TEST FUNCTION

The ADXRS300 includes a self-test feature that actuates each of the sensing structures and associated electronics in the same manner as if subjected to angular rate. It is activated by standard logic high levels applied to inputs ST1(5F, 5G) or ST2(4F, 4G), or both. ST1 will cause a voltage change at RATEOUT equivalent to typically $-280mV$ and ST2 will cause an opposite $+280mV$ change. The self-test response follows the viscosity temperature dependence of the package atmosphere, approximately $0.25 \%/^{\circ}C$.

Activating both ST1 and ST2 simultaneously is not damaging. As ST1 and ST2 are not necessarily closely matched, actuating both simultaneously may result in an apparent null bias shift.

CONTINUOUS SELF-TEST

The one-chip integration of the ADXRS300 gives it higher reliability than is obtainable with any other high volume manufacturing method. Also, it is manufactured under a mature BIMOS process which has field-proven reliability. As an additional failure-detection measure, power-on self-test can be performed. However, some applications may warrant continuous self-test while sensing rate. Application notes outlining continuous self test techniques are available.

PRELIMINARY TECHNICAL DATA

SURFACE-MOUNT BGA (BOTTOM VIEW)

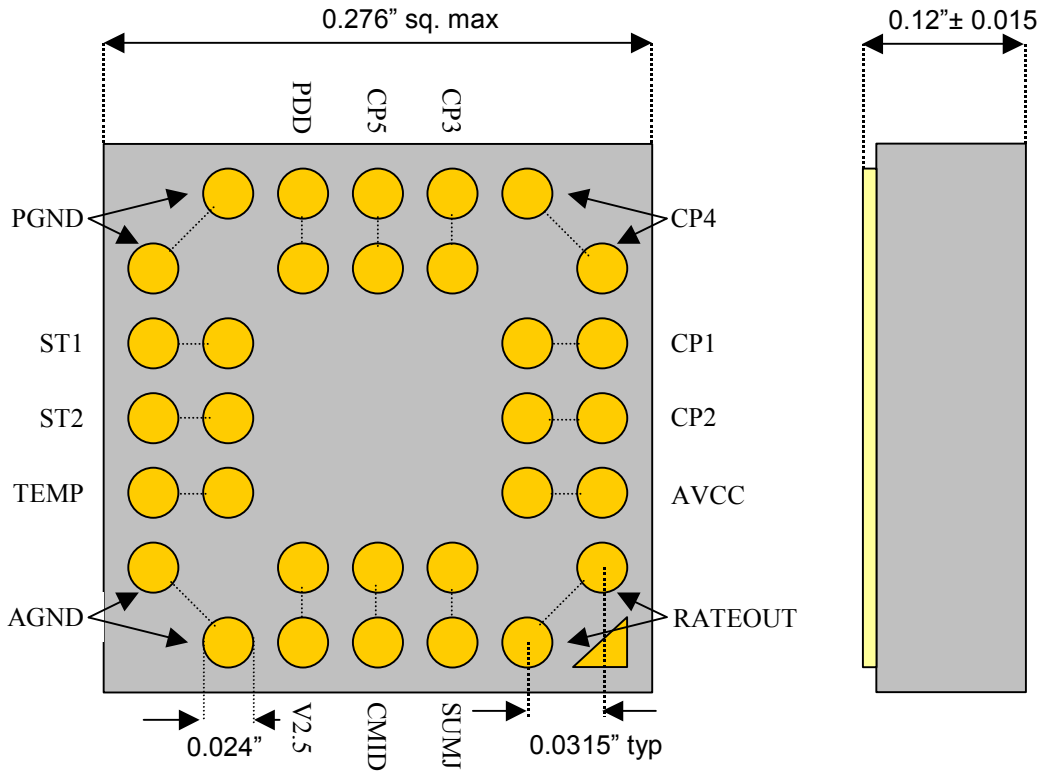

NOTE: Metal lid is internally connected to AGND.